

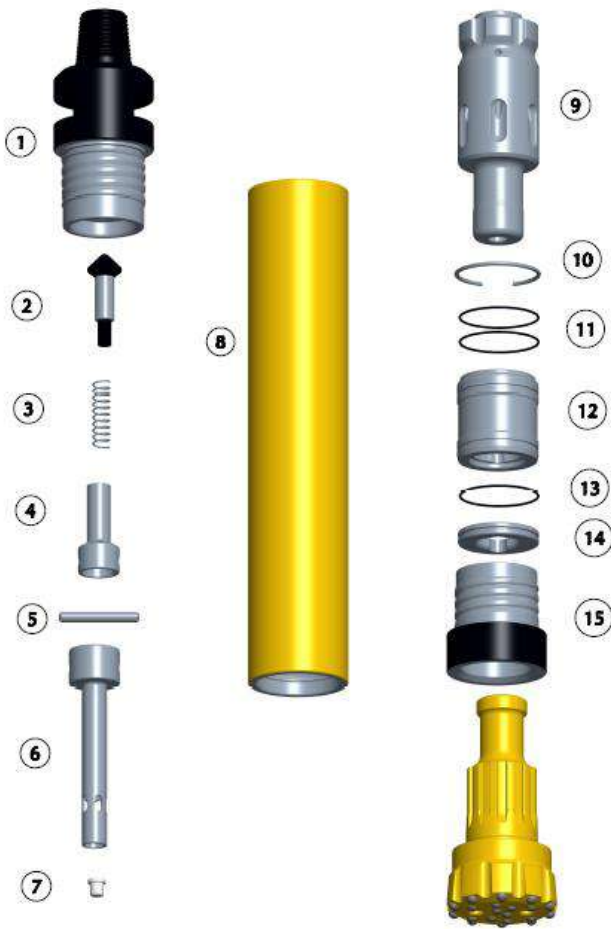

KGR D65 HAMMER



Item	Part Number	Description	Wt in Kgs
	KD65AS01	KGR-D65 (3 1/2" A.P.I. Reg. Pin)	89.2
1	KD65TS01	Top Sub (3 1/2" A.P.I. Reg. Pin)	18.25
2	KD65CV01	Check Valve	
3	KD65SG01	Spring	
4	KD65TV01	Top Valve	0.6
5	KD65LP01	Lock Pin	
6	KD65CT01	Control Tube	1.5
7	KD65CK01	Choke	
8	KD65WS01	Wear Sleeve	33.5
9	KD65PS01	Piston	19
10	KD65PR01	Piston Retainer Ring	
11	KD65OR01	"O" Rings For Guide Bush	
12	KD65GB01	Guide Bush	5.8
13	KD65OR02	Bit Retainer "O" Ring	
14	KD65BR01	Bit Retainer Ring	1
15	KD65FC01	Front Chuck	6.5
Service Kit(Item 3,7,11&13)			

Specifications

	Metric	Imperial
Hammer Outside Diameter	148mm	5.8"
Hammer Length (Without Bit, Top Sub to Front Chuck)	931mm	36.65"
Hammer Weight (Without Bit)	89.2Kg	198.4Lbs
Drill Bit Shank Type	D65(M6)	
Drill Bit Hole Size	165mm-203mm	6.5"-8"
Piston Weight	19 Kg	41.9"Lbs
Piston Stroke	90mm Approx.	3.54" Approx.
Top Sub Spanner Flat Size	90mm A/F	3.54" A/F

D65 Air Consumption, CFM

	150	200	250	300	350	400
CFM	350	600	850	1120	1400	1720