

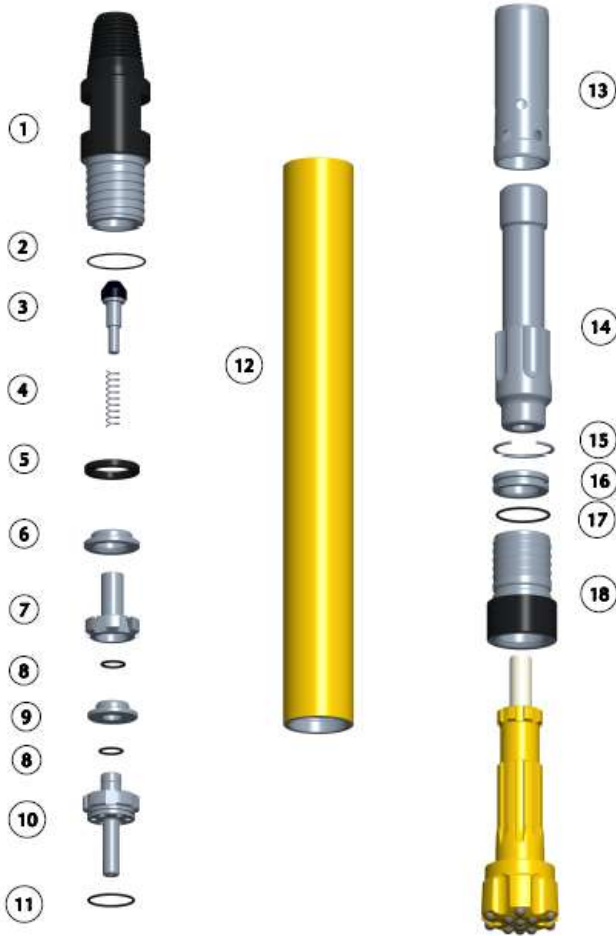

# KGR DHD3.5 HAMMER



Item	Part Number	Description	Wt in Kgs
	K35DHAS01	KGR-DHD35 (2 3/8" A.P.I. Reg. Pin)	20.5
1	K35DHTS01	Top Sub (2 3/8" A.P.I. Reg. Pin)	4.9
2	K35DHOR01	"O" Ring For Top Sub	
3	K35DHCV01	Check Valve	
4	K35DHSG01	Spring	
5	K35DHBG01	Buffer Ring	
6	K35DHSR01	Top Sub Spacer	0.1
7	K35DHTV01	Top Valve	0.3
8	K35DHOR02	"O" Ring For Top Valve & Rocker Valve	
9	K35DHRV01	Rocker Valve	
10	K35DHBV01	Bottom Valve	0.7
11	K35DHOR03	"O" Ring For Bottom Valve	
12	K35DHWS01	Wear Sleeve	8.1
13	K35DHIC01	Inner Cylinder	0.9
14	K35DHPS01	Piston	3.9
15	K35DHPR01	Piston Retainer Ring	
16	K35DHBR01	Bit Retainer Ring	0.2
17	K35DHOR04	"O" Ring For Bit Retainer Ring	
18	K35DHFC01	Front Chuck	1.5
Service Kit(2,4,5,8,11&17)			

## Specifications

	Metric	Imperial
Hammer Outside Diameter	78mm	3.07"
Hammer Length (Without Bit, Top Sub to Front Chuck)	776.6mm	30.57"
Hammer Weight (Without Bit)	20.5Kg	45.2Lbs
Drill Bit Shank Type	DHD3.5	
Drill Bit Hole Size	90mm-100mm	3.54"-3.93"
Piston Weight	3.9 Kg	8.6"Lbs
Piston Stroke	80mm Approx.	3.14" Approx.
Top Sub Spanner Flat Size	57mm A/F	2.24" A/F

## DHD3.5 Air Consumption, CFM

PSI	100	150	200	250
CFM	55	85	130	185