

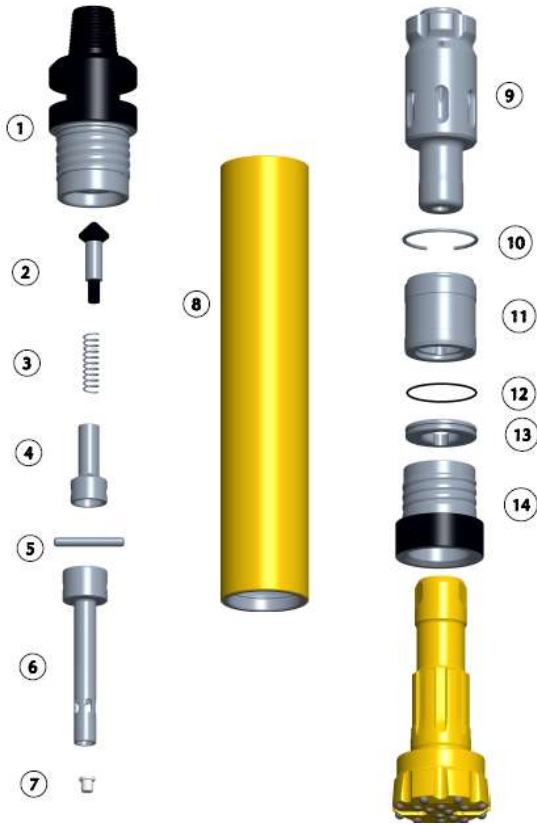

KGR DHD360 HAMMER



Item	Part Number	Description	Wt in Kgs
	K60DHAS01	KGR-DHD360 (3 1/2" A.P.I. Reg. Pin)	93.8
1	K60DHTS01	Top Sub (3 1/2" A.P.I. Reg. Pin)	18.2
2	K60DHCV01	Check Valve	
3	K60DHSG01	Spring	
4	K60DHTV01	Top Valve	0.7
5	K60DHLP01	Lock Pin	0.2
6	K60DHCT01	Control Tube	1.5
7	K60DHCK01	Choke	
8	K60DHWS01	Wear Sleeve	36.1
9	K60DHPS01	Piston	19
10	K60DHPR01	Piston Retainer Ring	
11	K60DHGB01	Guide Bush	7.8
12	K60DHOR01	Bit Retainer "O" Ring	
13	K60DHBR01	Bit Retainer Ring	0.8
14	K60DHFC01	Front Chuck	7.8
Service Kit(Item 3,7,&12)			

Specifications	Metric	Imperial
Hammer Outside Diameter	148mm	5.8"
Hammer Length (Without Bit, Top Sub to Front Chuck)	1008mm	38.42"
Hammer Weight (Without Bit)	93.8Kg	206.8Lbs
Drill Bit Shank Type	DHD360	
Drill Bit Hole Size	165mm-203mm	6.5"-8"
Piston Weight	19.0 Kg	41.9"Lbs
Piston Stroke	90mm Approx.	3.54" Approx.
Top Sub Spanner Flat Size	90mm A/F	3.54" A/F

DHD360 Air Consumption, CFM

PSI	150	200	250	300	350	400
CFM	370	600	860	1120	1420	1740