

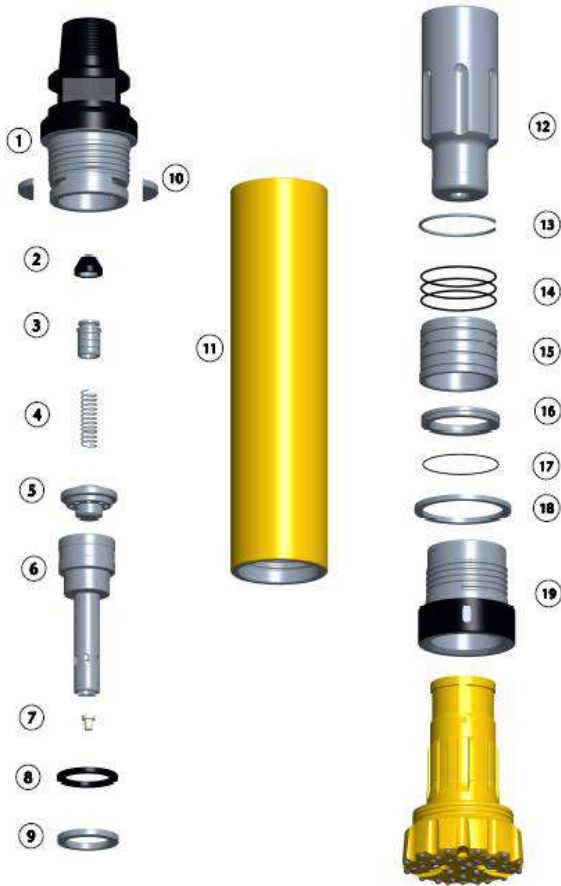

KGR RK3 HAMMER



Item	Part Number	Description	Wt in Kgs
	KRK3AS01	KGR-RK3 (6 5/8" A.P.I. Reg. Pin)	310
1	KRK3TS01	Top Sub (6 5/8" A.P.I. Reg. Pin)	64.2
2	KRK3CC01	Check Valve Cap	
3	KRK3CV01	Check Valve	
4	KRK3SG01	Spring	
5	KRK3AD01	Air Distributor	3.1
6	KRK3CT01	Control Tube	10.5
7	KRK3CK01	Choke	
8	KRK3BG01	Buffer Ring	
9	KRK3MS01	Metal Spacer	
10	KRK3LP01	Lock Plate	
11	KRK3WS01	Wear Sleeve	118.8
12	KRK3PS01	Piston	73.5
13	KRK3PR01	Piston Retainer Ring	
14	KRK3OR01	'O' Ring For Guide Bush	
15	KRK3GB01	Guide Bush	9.3
16	KRK3BR01	Bit Retainer Ring	1.9
17	KRK3OR02	'O' Ring For Bit Retainer Ring	
18	KRK3FS01	Front Chuck Metal Spacer	
19	KRK3FC01	Front Chuck	22.6
Service Kit(Item 2,3,4,7,8,14&17)			

Specifications

	Metric	Imperial
Hammer Outside Diameter	240mm	9.44"
Hammer Length (Without Bit, Top Sub to Front Chuck)	1220mm	48.03"
Hammer Weight (Without Bit)	310Kg	683.43Lbs
Drill Bit Shank Type	RK3	
Drill Bit Hole Size	305mm-457mm	12"-18"
Piston Weight	73.5 Kg	162.03Lbs
Piston Stroke	85mm Approx.	3.34" Approx.
Top Sub Spanner Flat Size	156mm A/F	6.14" A/F

RK3 Air Consumption, CFM

PSI	150	200	250	300	350	400
CFM	660	1020	1420	1870	2360	2880