

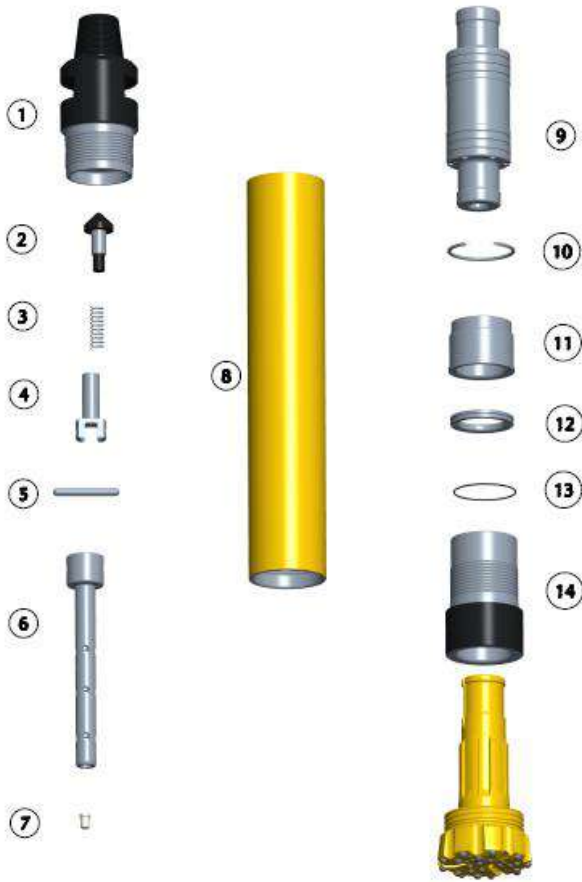

KGR SD8 HAMMER



Item	Part Number	Description	Wt in Kgs
	K80SDAS01	KGR-SD8 (4 1/2" A.P.I. Reg. Pin)	158.5
1	K80SDTS01	Top Sub (4 1/2" A.P.I. Reg. Pin)	35.7
2	K80SDCV01	Check Valve	
3	K80SDSG01	Spring	
4	K80SDTV01	Top Valve	1.4
5	K80SDLP01	Lock Pin	
6	K80SDCT01	Control Tube	3.2
7	K80SDCK01	Choke	
8	K80SDWS01	Wear Sleeve	52.2
9	K80SDPS01	Piston	38.2
10	K80SDPR01	Piston Retainer Ring	
11	K80SDGB01	Guide Bush	7.5
12	K80SDOR01	"O" for Bit Retainer Ring	
13	K80SDBR01	Bit Retainer Ring	1.4
14	K80SDFC01	Front Chuck	18
Service Kit(Item 2,3,7&12)			

Specifications

	Metric	Imperial
Hammer Outside Diameter	177mm	6.97"
Hammer Length (Without Bit, Top Sub to Front Chuck)	1168mm	45.98"
Hammer Weight (Without Bit)	158.5Kg	102.3Lbs
Drill Bit Shank Type	SD8	
Drill Bit Hole Size	203mm-305mm	8"-12"
Piston Weight	38.2 Kg	84.2"Lbs
Piston Stroke	80mm Approx.	3.15" Approx.
Top Sub Spanner Flat Size	115mm A/F	3.54" A/F

SD8 Air Consumption, CFM

PSI	100	150	200	300	400	500
CFM	215	390	595	1090	1710	2390